

1. 適用範圍 / SCOPE

2410LT 系列慢速保險絲，適用於一般電子設備。

2410LT series Slo-Blo Fuse, used in electronic equipment.

2. 產品編碼 / Part Numbering

例「example」：

2410LT	0.5A-6.3A	250Vac/125Vdc		① 系列號/series Number
2410LT	3.15A/4A/5A	a.c. 250V	  	② 特性符號/Characteristic Symbol
↓	↓	↓	↓	③ 額定電流/Rated Current
①	②	③	④	④ 額定電壓/Rated Voltage

3. 額定電流和額定電壓/ RATED CURRENT AND RATED VOLTAGE

額定電流 / Rated Current:

0.5A~6.3A

額定電壓 / Rated Voltage:

250 V ac

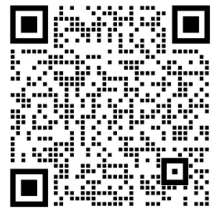

4. 標示 / MARKING

保險絲上需有下列標示/The fuses shall have the following marking

① 產品系列標識 / Series type Logo : LT

② 額定電流 / Rated Current (A): ___A

注意 / Note :

對標示的大小和位置沒有規定 / Size and position of the markings shall not be provided.

5. 外觀及形狀 / APPEARANCES AND CONFIGURATION

5-1 外觀：無顯著的汙點、鐵銹或裂紋；標示應容易辨識。

Appearances : There shall not be any remarkable stain, rust or crack on the appearances; marking shall be easily legible.

5-2 形狀：表面貼裝式保險絲

Configuration : Surface Mount Fuse.

6. 工程圖和結構 / OUTLINE DRAWING AND STRUCTURE

6-1 工程圖 (單位 : mm) / Outline Drawing and Dimensions (Unit: mm)

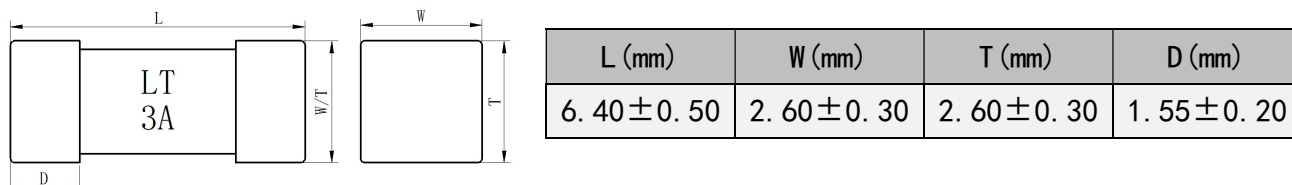

6-2 結構 / Structure

元件 Component	材質 Material	數量 Quantity
銅帽 Cap	黃銅鍍銀 Brass with Silver plated	2
本體 Body	陶瓷管 Ceramic tube	1

7. 產品特性 / PRODUCT CHARACTERISTICS

編號 No.	項目 Item	內容 Content	參考標準 Reference standard
1	絕緣阻抗 Insulation resistance (after opening)	10,000 ohms minimum	MIL-STD-202G, Method 302 Test Condition A
2	可焊性 Solderability	T=245°C±5°C, t=3±0/-0.5s, Cover ≥95%	MIL-STD-202G, Method 208H
3	耐焊接熱 Soldering heat resistance	10 sec at 260 °C ΔR :<10%	MIL-STD-202G, Method 210F Test Condition B
4	熱衝擊 Thermal Shock	5 cycles between -65°C/+125°C 15minutes ; each extreme ΔR :<10%	MIL-STD-202G, Method 107 Test Condition B
5	機械衝擊 Mechanical Shock	100Gs Peak amplitude , sawtooth wave 6 ms duration , 3 cycles XYZ+xyz=18 shocks. ΔR :<10%	MIL-STD-202G, Method 213 Test Condition 1
6	高/低溫儲存 High/Low Temperature Storage	T=125°C±2°C , 96hours , T=-55°C±3°C , 96hours ΔR : <10%	IEC60068-2-1 / IEC60068-2-2
7	抗潮濕性 Moisture Resistance	85°C±3°C,80% ~ 90%RH 10 cycles ΔR :<10%	MIL-STD-202, Method 106
8	振動 Vibration	10-55-10 Hz Sweep in 1 minute , 0.03 in amplitude . 2hours in each of XYZ planes=6hours total. ΔR : <10%	MIL-STD-202 Method 201 (10-55Hz)
9	鹽霧實驗 Salt spray	5% salt solution , 48hours ΔR : <10%	MIL-STD-202G, Method 101E, Test Condition B

8. 電氣特性 / ELECTRICAL CHARACTERISTICS

8-1 熔斷 / 電流特性 : Pre-Arcing Time / Current Characteristic (limits)

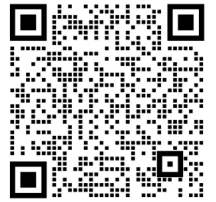

RATED CURRENT	1 In	2 In
0.5A~6.3A	4hrs Min.	120s Max.

8-2 產品規格/Specification

額定電流 Rated Current(A)	額定電壓 Rated Voltage(V)	分斷能力 Breaking Capacity	Typical Cold DCR (mΩ)	Normal I ² T** (A2s)
0.5	250V	250Vac 50A 125Vdc 80A	260	0.3
0.63			230	0.48
0.75			190	0.84
0.8			150	1.28
1			117	3.1
1.25			85	4.1
1.5			75	8.0
1.6			72	8.9
2			49	10.3
2.5			39	17.2
3			27	25.6
3.15			25	26.6
3.5			20	33.7
4			15	43.4
4.8			14	49.1
5			13	50.5
6.3	10	68.3		

** I²T Values stated for 10 times of rated current

Agency Approval Table Key: V=Approve or Certified,P=Pending and Blank=Not Approval

9. 環境特性 / ENVIRONMENTAL CHARACTERISTIC

操作溫度範圍: -55°C ~ 125°C / Operating Temperature: -55°C ~ 125°C

若貴司操作環境溫度超出25±5°C範圍，在選用保險絲規格時，需考慮操作環境溫度對保險絲的影響。

請參照：溫度-電流曲線圖。

When choosing the fuse's specification, if the operating environmental temperature beyond the scope from 20~30°C, you should consider the environmental temperature's affection to fuses.

please refer:



Temperature-Current curve:

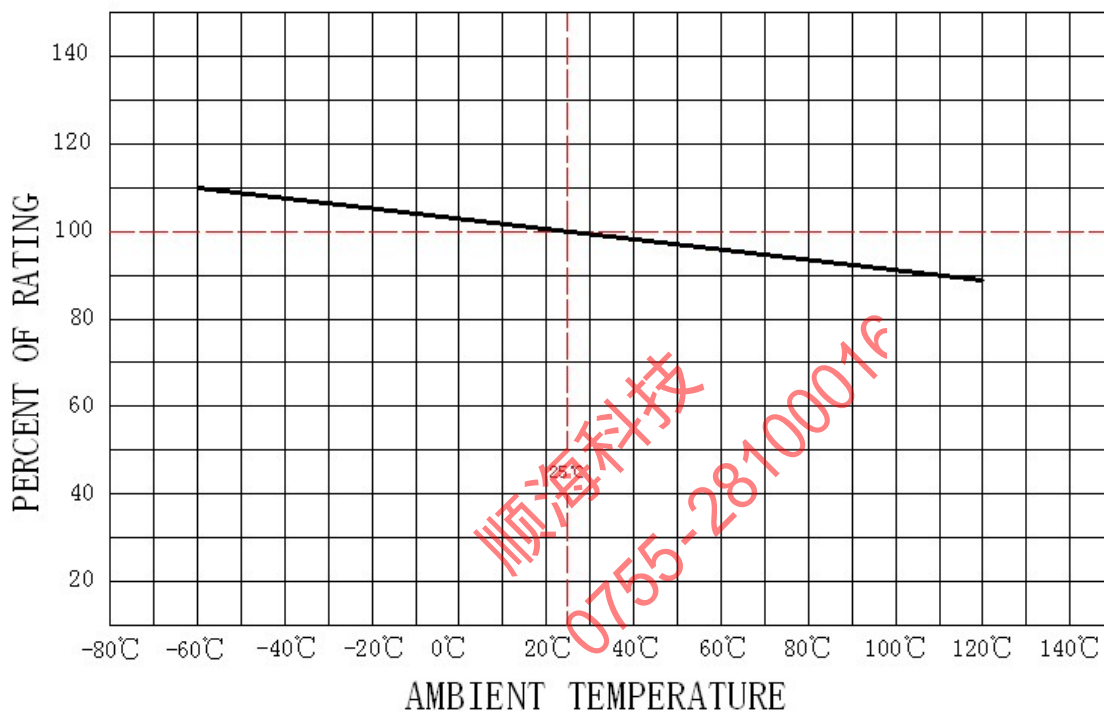

10. 安裝方式及條件 / INSTALLATION WAY AND PARAMETERS

10-1 建議如下圖安裝方式安裝，並滿足所要求的尺寸。

Propose that the following picture installation way is installed, and satisfied the required size.

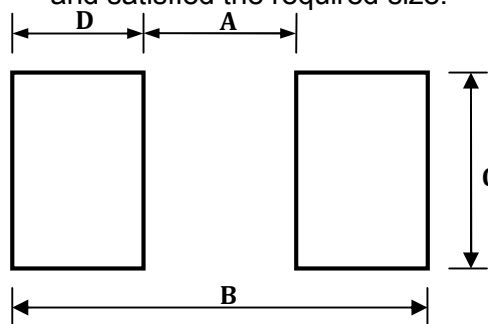

Dimensions	A(mm)	B(mm)	C(mm)	D(mm)
2410LT	3.20±0.30	9.6±0.30	3.9±0.30	3.2±0.30

10-2 建議客戶焊接參數 / Recommended Customer Soldering Parameters



1. Infrared Reflow:

Temperature : 260°C

Time : 5sec Max.

Recommend Reflow profile

Reflow Condition		Pb-Free assembly
Preheating	-Temperature Min (Ts(min))	150 °C
	-Temperature Max (Ts(max))	200 °C
	-Time	60~120 Secs
Soldering	-Temperature (TL)(Liquidus)	235 °C
	-Time Max (TL)	20~40Secs
	-Peak Temperature (Tp)	Max 260 °C
	-Time Max (Tp)	5 Secs

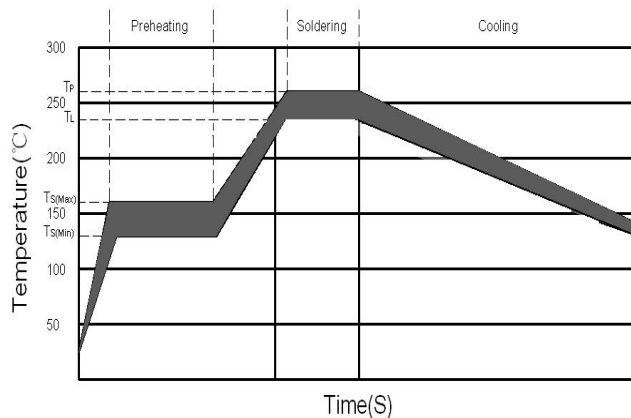

2. Wave soldering

Reservoir Temperature : 260°C

Time in Reservoir : 10sec Max.

3. Hand Soldering :

Temperature : 300°C

Time : 2sec Max.

Soldering iron avoid touch Cap.

順海科技
 0755-28100016

11.其他使用注意事項 / OTHER NOTICE IN USED

符合本公司可能的其它檔的要求。

It could be in conformance with another file which made by our company.

12.安全認證及編號 / STANDARDS AND APPROVALS

UL	E56092
TUV	R50485936 (3.15A/4A/5A)
CQC	CQC20012273793 (3.15A/4A/5A)

13. 包裝訊息 / PACKING INFORMATION

13-1 包裝數量、重量 / QUANTITY & WEIGHT

型號 Type Number	數量(pcs) Quantity(pcs)
2410LT	1,000



13-2 捲輪規格/ Reel & Tape specifications

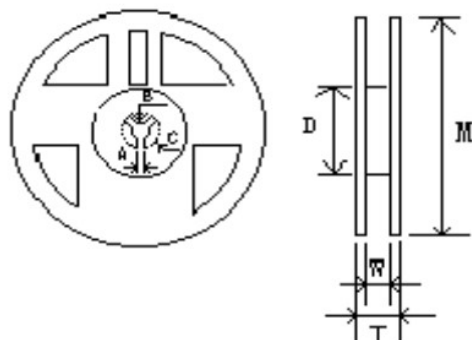

M(mm)	178.00±2.00
W(mm)	12.50±1.50
T(mm)	14.50±1.50
A(mm)	2.00±0.50
B(mm)	13.00±0.50
C(mm)	21.00±0.50
D(mm)	58.00±2.00

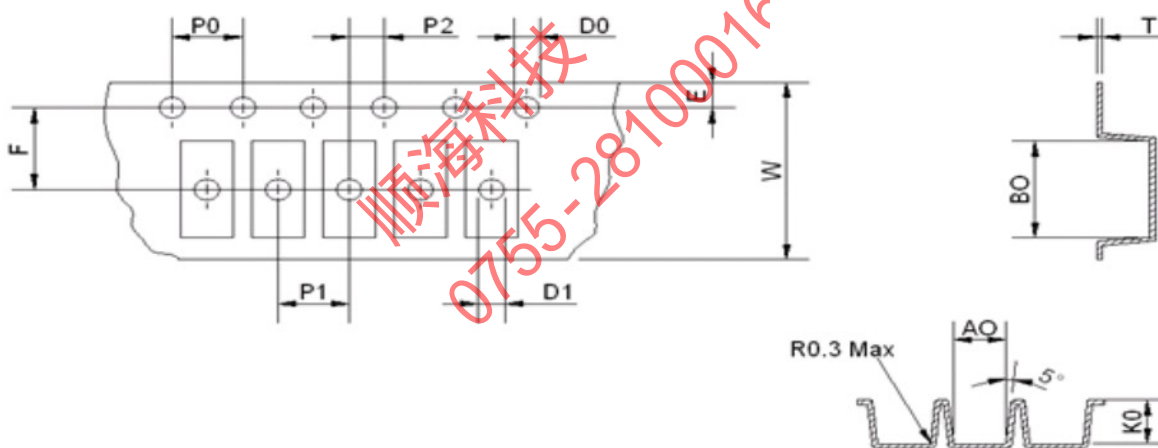

A0(mm)	B0(mm)	K0(mm)	P0(mm)	P1(mm)	P2(mm)
3.00 ± 0.10	7.00 ± 0.10	3.00 ± 0.10	4.00 ± 0.10	4.00 ± 0.10	2.00 ± 0.10
E(mm)	F(mm)	D0(mm)	D1(mm)	W(mm)	T(mm)
1.75 ± 0.10	5.50 ± 0.10	1.50 ± 0.10	1.50 ± 0.25	12.0 ± 0.15	0.25 ± 0.05

13-3 密封膠膜剝離強度要求 / Peeling Strength of Seal Tape

F = 剝離強度 : 0.1 – 1.0N (10 - 100gf)

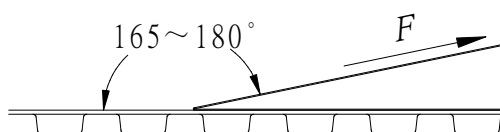

14.其他 / OTHERS

14-1 如果在使用中有超出本規格書的要求，必須經由雙方協商確認。

In the event that an impropriety is found beyond this specification ,it shall be fixed by mutual agreement between the parties.

14-2 如果本規格書有不適當的情況，必須通過雙方協商並由本公司修改。

In the event that an impropriety is found in this specification , SUZHOU WALTER ELECTRONIC CO., LTD. shall amend it by mutual agreement between the parties.

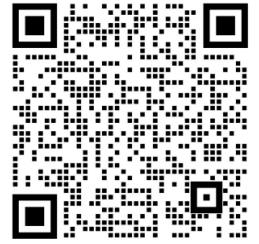

順海科技
0755-28100016

版次	製作	確認	審核
第4版	蔡小梅 2021/03/05	程 錦 2021/03/05	Russel.Hsu 2021/3/5



UL iQ for Fuses



Fuses

E56092

Guide Information

SUZHOU WALTER ELECTRONIC CO LTD

NO.99 Xinli Road, Fenhu Technic Development Zone, Wujiang Jiangsu 215211 CN

2410LT

Supplemental micro fuses: surface mount, cartridge enclosed

<u>Size</u> mm(in)	<u>Amps</u> (A)	<u>Volts</u> (V)	<u>Interrupting</u> <u>Rating (A)</u>
6.4 x 2.6 x 2.6 (0.25 x 0.10 x 0.10)	0.5 - 6.3	250Vac	50
	0.5 - 6.3	125Vdc	80

Report Date: 2019-01-21

Last Revised: 2019-10-17

© 2019 UL LLC



顺海科技
0755-28100016

Zertifikat

Certificate



Zertifikat Nr. *Certificate No.* R 50485936
Blatt *Sheet* 0001

Ihr Zeichen *Client Reference* Unser Zeichen *Our Reference* 05-YFC-NN20H561 001
Ausstellungsdatum *Date of Issue* 11.11.2020 (day/mo/yr)

Genehmigungsinhaber *License Holder* Fertigungsstätte *Manufacturing Plant*
Suzhou Walter Electronic Co., Ltd. Suzhou Walter Electronic Co., Ltd.
Fenhu Technic Development Zone, Luxu Fenhu Technic Development Zone, Luxu
Wujiang City Wujiang City
Jiangsu Jiangsu
P.R. China P.R. China

Prüfzeichen *Test Mark*



Geprüft nach *Tested acc. to*
EN 60127-1:2006+A1+A2
EN 60127-7:2016
IEC 60127-1:2006+A1+A2
IEC 60127-7:2015

Zertifiziertes Produkt (Geräteidentifikation) *Certified Product (Product Identification)*

Lizenzentgelte - Einheit
License Fee - Unit

Fuse Link (Miniature fuse-links)

Type Designation : 2410LT
Trademark : Walter (Logo)
Rated Voltage : AC 250V
Rated Current : 3.15A, 5A
T/I Characteristic : see appendix 1
Rated Breaking Capacity : 50A
Dimension : 2.6mmx6.4mm, without pigtail

7

Remark : The labelling requirements acc. to EU Directive 2001/95 have to be observed for distribution within the EEA.

7

ANLAGE (Appendix) : 1

Dem Zertifikat liegt unsere Prüf- und Zertifizierungsordnung zugrunde und es bestätigt die Konformität des Produktes mit den oben genannten Standards und Prüfgrundlagen. Zusätzliche Anforderungen in Ländern, in denen das Produkt in Verkehr gebracht werden soll, müssen zusätzlich betrachtet werden. Die Herstellung des zertifizierten Produktes wird überwacht.
This certificate is based on our Testing and Certification Regulation and states the conformity of the product with the standards and testing requirements as indicated above. Any additional requirements in countries where the product is going to be marketed have to be considered additionally. The manufacturing of the certified product is subject to surveillance.

TÜV Rheinland LGA Products GmbH, Tillystraße 2, 90431 Nürnberg

Tel : +49 221 806-1371 e-mail: cert-validity@de.tuv.com
Fax: +49 221 806-3935 http://www.tuv.com/safety



Zertifikat

Certificate



Zertifikat Nr. *Certificate No.*
R 50485936

Blatt *Sheet*
0002

Ihr Zeichen *Client Reference*

Unser Zeichen *Our Reference*

Ausstellungsdatum

Date of Issue

05-YFC-NN20H561 002

23.02.2021

(day/mo/yr)

Genehmigungsinhaber *License Holder*

Suzhou Walter Electronic Co., Ltd.
Fenhu Technic Development Zone, Luxu
Wujiang City
Jiangsu
P.R. China

Fertigungsstätte *Manufacturing Plant*

Suzhou Walter Electronic Co., Ltd.
Fenhu Technic Development Zone, Luxu
Wujiang City
Jiangsu
P.R. China

Prüfzeichen *Test Mark*



Geprüft nach *Tested acc. to*

EN 60127-1:2006+A1+A2

EN 60127-7:2016

IEC 60127-1:2006+A1+A2

IEC 60127-7:2015

Zertifiziertes Produkt (Geräteidentifikation)

Certified Product (Product Identification)

Lizenzentgelte - Einheit

License Fee - Unit

Fuse Link (Miniature fuse-links)

as page 0001

Addition

Rated Current : 4A

1

Remark : The labelling requirements acc. to EU Directive 2001/95 have to be observed for distribution within the EEA.

1

ANLAGE (Appendix) : 1.1

Dem Zertifikat liegt unsere Prüf- und Zertifizierungsordnung zugrunde und es bestätigt die Konformität des Produktes mit den oben genannten Standards und Prüfgrundlagen. Zusätzliche Anforderungen in Ländern, in denen das Produkt in Verkehr gebracht werden soll, müssen zusätzlich betrachtet werden. Die Herstellung des zertifizierten Produktes wird überwacht. This certificate is based on our Testing and Certification Regulation and states the conformity of the product with the standards and testing requirements as indicated above. Any additional requirements in countries where the product is going to be marketed have to be considered additionally. The manufacturing of the certified product is subject to surveillance.

TÜV Rheinland LGA Products GmbH, Tillystraße 2, 90431 Nürnberg

Tel.: +49 221 806-1371 e-mail: cert-validity@de.tuv.com

Fax: +49 221 806-3935 http://www.tuv.com/safety

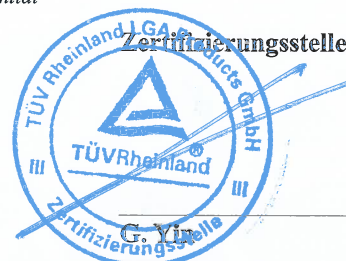



产品认证证书

证书编号: CQC20012273793

发证日期: 2021年02月25日

有效期至: 2025年11月19日

委托人名称 苏州华德电子有限公司
及注册地址 江苏省吴江市汾湖经济技术开发区(芦墟)

制造商名称 苏州华德电子有限公司
及注册地址 江苏省吴江市汾湖经济技术开发区(芦墟)

生产企业名称 苏州华德电子有限公司
及生产地址 江苏省吴江汾湖经济开发区新黎路99号

产品名称和系列、规格、型号 特殊应用的小型熔断体
2410LT 3.15A a.c. 250V、2410LT 4A a.c. 250V、2410LT 5A a.c. 250V(额定分断能力: 50A, 主要尺寸: 6.4mm×2.6mm×2.6mm)

产品标准和技术要求 GB/T 9364.1-2015;GB/T 9364.7-2016

认证模式 产品型式试验+初次工厂检查+获证后监督

上述产品符合 CQC11-462125-2018 认证规则的要求, 特发此证。
证书有效期内本证书的有效性依据发证机构的定期监督获得保持。

可通过扫描下方二维码或登录国家认监委网站 (www.cnca.gov.cn) 查验证书信息



签发: 陆楠

中国质量认证中心





PRODUCT CERTIFICATION

CERTIFICATE NO.: CQC20012273793

Valid from: Feb.25,2021

Valid until: Nov.19,2025

NAME AND REGISTERED ADDRESS OF THE APPLICANT Suzhou Walter Electronic Co., Ltd.
Fenhu Technic Development Zone, Luxu, Wujiang City, Jiangsu

NAME AND REGISTERED ADDRESS OF THE MANUFACTURER Suzhou Walter Electronic Co., Ltd.
Fenhu Technic Development Zone, Luxu, Wujiang City, Jiangsu

NAME AND LOCATION OF THE FACTORY Suzhou Walter Electronic Co., Ltd.
South of Xinli Road, Fenhu Technic Development Zone, Luxu, Wujiang City, Jiangsu

PRODUCT NAME, MODEL AND SPECIFICATION Miniature Fuse-links for Special applications
2410LT 3.15A a.c. 250V、2410LT 4A a.c. 250V、2410LT 5A a.c. 250V(额定分断能力：50A，主要尺寸：6.4mm×2.6mm×2.6mm)

THE STANDARDS AND TECHNICAL REQUIREMENTS FOR THE PRODUCTS GB/T 9364.1-2015;GB/T 9364.7-2016

TYPE OF CERTIFICATION SCHEMES Type Testing of Product + Initial Factory Inspection + Follow up Factory Inspection

This is to certify that the above mentioned product(s) complies with the requirements of certification rules of CQC11-462125-2018.
The validity of the certificate is subject to positive result of the regular follow up inspection by issuing certification body until the expiry date.

The certificate information is available through the QR code below or CNCA's website: www.cnca.gov.cn



SIGNATURE:

陆梅

CHINA QUALITY CERTIFICATION CENTRE

